

6watt Recessed Square Light

Model No.

RS-SRS3, RS-SRS3-BC, RS-SRS5, RS-SRS5-BC

The Redilight 6watt small recessed downlight was designed with emphasis on both aesthetics and performance.

When combining a superior finish with the exceptional performance of SMD LED's you have a light that lasts for many years suiting almost any application.

Note: 'The splitter box is to be used in conjunction with the 6watt downlights only. The 6watt downlights plug into the splitter box first to create either a 12 or 24watt load, splitter box lead is then plugged into the Redilight Driver'.

Specifications

Construction	Aluminium
Finish	White Powder coated, Brushed Chrome
LED	SMD
Number of LED's	30
Drive voltage	29-32VDC constant current
Power	6watt
Lumens	600-700Lm
Colour Range	3000k or 5000k
Average Life	>50,000hrs
Beam Angle	120°
Environmental Conditions	IP20
Light Engine	Ceramic Substrate with aluminium PCB
Size	Overall 109x109mm, Cut out 90x90mm
Warranty	7 years
Diffuser	Acrylic (PMMA)



Dimensions

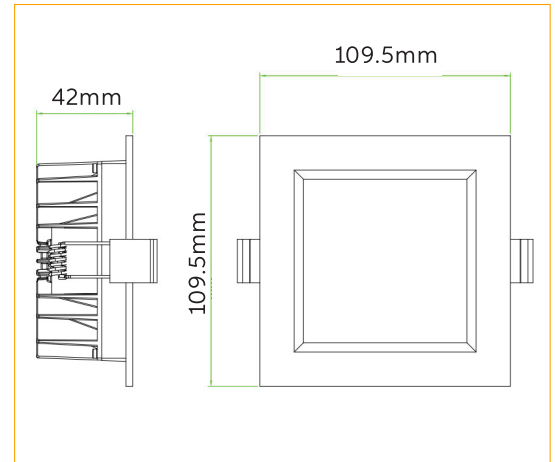

Photometric Data

