

## Heavy Duty Mounting Brackets

Redilight SPECTRA offers a Green Energy Solution for light starved areas in the home or office.

It operates on a sun-up, sun-down effect. As the sun rises the light gets brighter towards the middle of the day. The light intensity reduces as the sun sets in the afternoon.

Note: Optional Day/Night kits available for night time use.

### Kit Components

- A** 1x solar panel (150 or 250 watt)
- B** Redilight light fitting (Skyfixture)
- C** 20m of 2 core 1.84mm<sup>2</sup> DC cable
- D** 5m of pre-connected 4mm<sup>2</sup> DC cable
- E** Tile roof mounting bracket kit:
  - 4 x tile brackets
  - 4 x adjustable end clamps
  - 4 x rail lugs
  - 12 x 14g Type 17 Tek screws
- F** Metal roof mounting bracket kit:
  - 4 x tile brackets
  - 4 x adjustable end clamps
  - 4 x rail lugs
  - 12 x 14g Type 17 Tek screws
- G** 1x sticker to be placed in meter box
- H** Junction box
- I** 2x mounting rails

### Helpful Hints When Installing Solar Panels

- When determining a suitable location for the solar panel a northerly aspect is beneficial.
- Be mindful of potential shading from larger objects over the course of the day.
- ALWAYS adhere to local safety guidelines whenever working at height. A safety harness may be required.
- Visit [www.redilight.com](http://www.redilight.com) for installation videos.



## Solar Panel Installation

### Tile Roof Bracket Fixing

- Remove or kick up a tile directly above a roof truss. Do the same either 600mm or 900mm to the left or right to find another roof truss.
- Fix a tile bracket to the top chord of the truss by screwing 3 x 65mm tech screws into it (Fig 1). Please note, you may need to pre-drill hole.
- Once screwed into place just replace or pull down the top tile back over the bracket for a weather proof seal.
- Repeat this step 4 times as you will need 2 brackets for the bottom rail (I) and 2 brackets for the top rail (I).

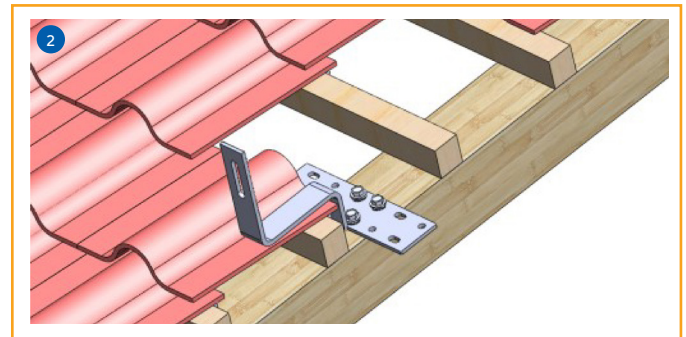
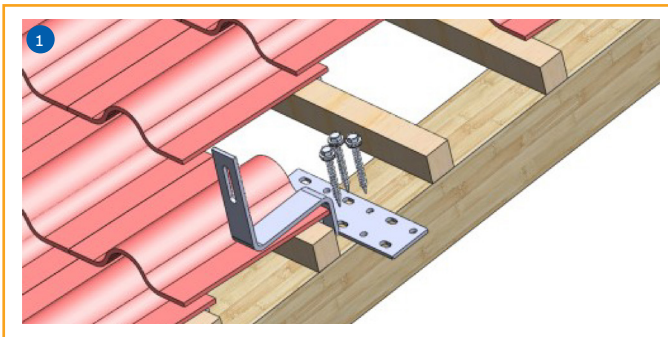

Tip: If the tile bracket is making the tile sit up you can do two things - use a pair of pliers to pinch out some tile on the underside in line with the bracket, OR use a grinder to trim a small section so the tile will sit snugly over the bracket.

### Metal Roof Bracket Fixing

- Simply unscrew existing roof screws that screw into the roof batten and use the same holes to mount the 4 x 'L' brackets that will support the rail.
- Be sure to use the supplied rubber washer under the bracket for a weather proof seal.

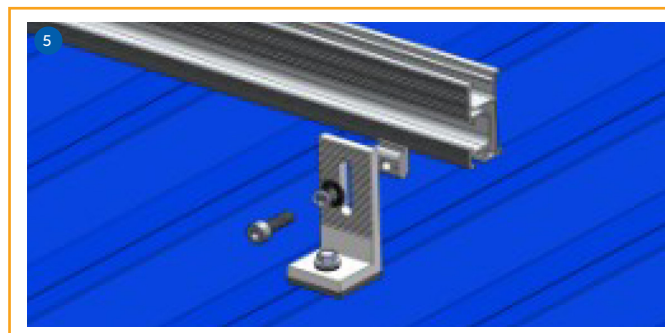
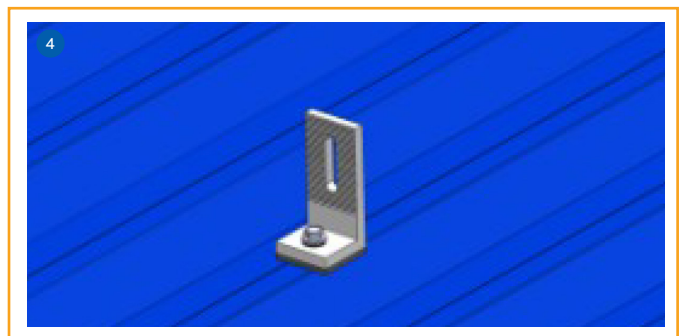
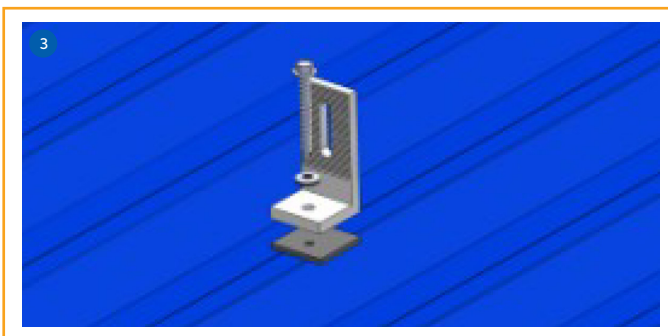

## Solar Panel Installation

### Secure Rail to Bracket

- Once you have securely fixed all 4 brackets you can now fix the top and bottom rail (I) to the brackets with the Allen key head screw, washers and nut modules provided.
- Tighten Allen key screws firmly. See Fig 6 & Fig 7
- Refer to Fig 11 for side profile of rail with screw lugs to fix rail and panel to bracket

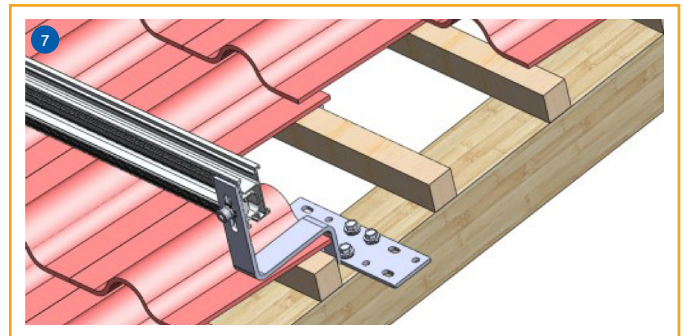
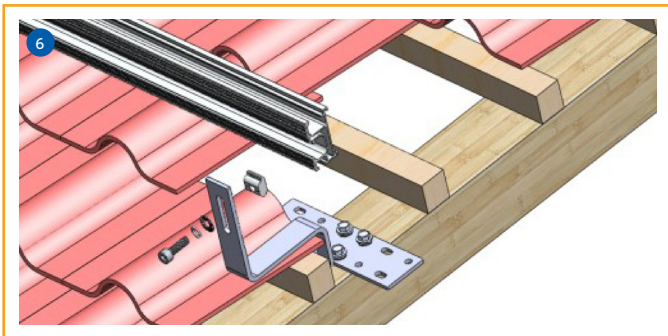

- Now that the rails have been secured to the mounting brackets you are now ready to mount the solar panel to the rails.
- Fix the solar panel to the rails by using the 4 end clamps supplied. Tighten the Allen head bolts on the end clamps firmly to secure the solar panel to both rails as shown below.

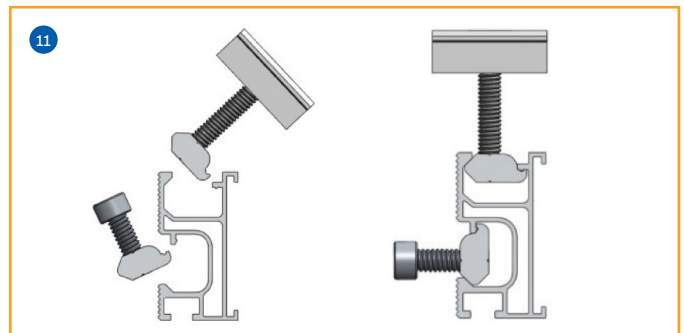
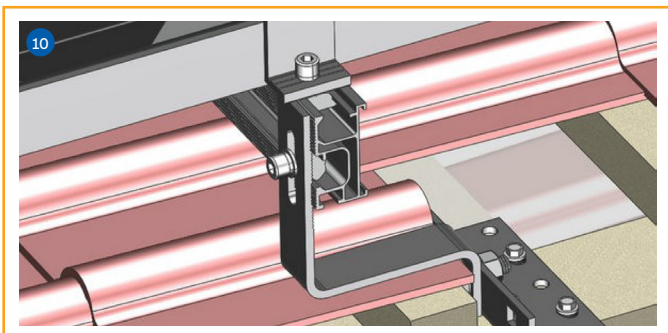
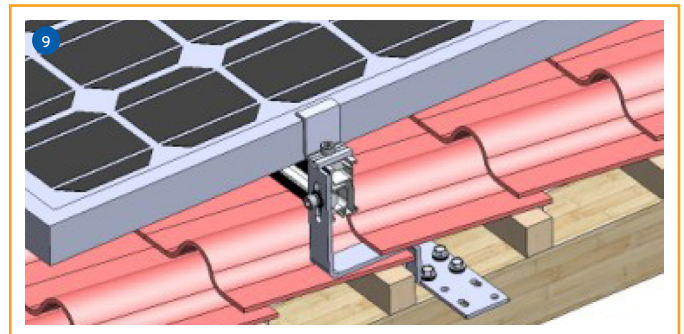
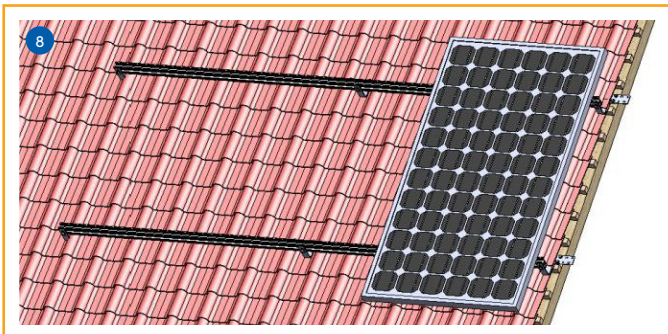

## Lighting Configurations

### 150 watt SPECTRA

Light fitting options: 2 x 48 watt / 5 x 24 watt / 10 x 12 watt / 20 x 6 watt / any combination up to 120 watts

- 12 The supplied junction box is for the termination of all cables coming from each light driver connecting them to the solar cable.

Try to centralise this junction box in the roof cavity between the lights being installed.

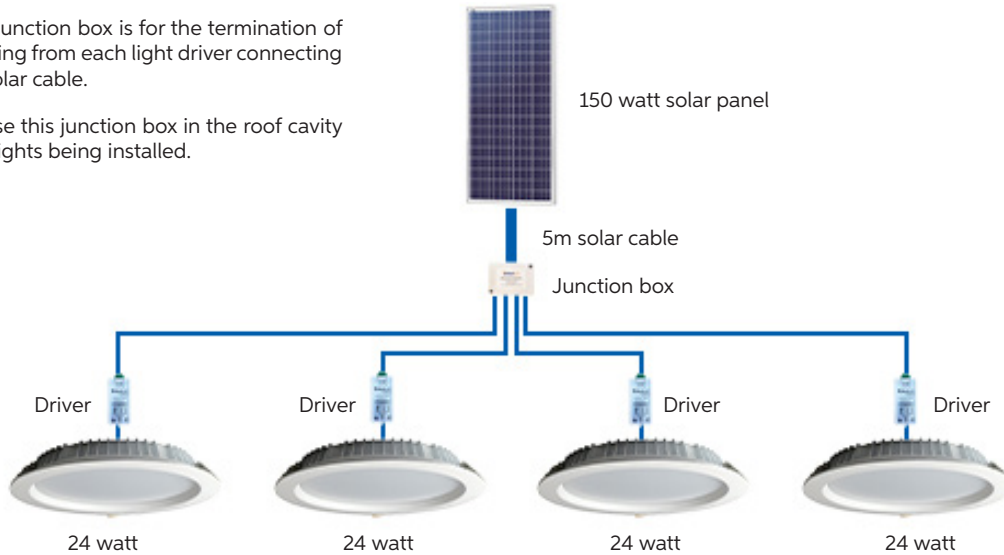

### 250 watt SPECTRA

Light fitting options: 4 x 48 watt / 8 x 24 watt / 16 x 12 watt / 32 x 6 watt / any combination up to 192 watts

- 13 The supplied junction box is for the termination of all cables coming from each light driver connecting them to the solar cable.

Try to centralise this junction box in the roof cavity between the lights being installed.

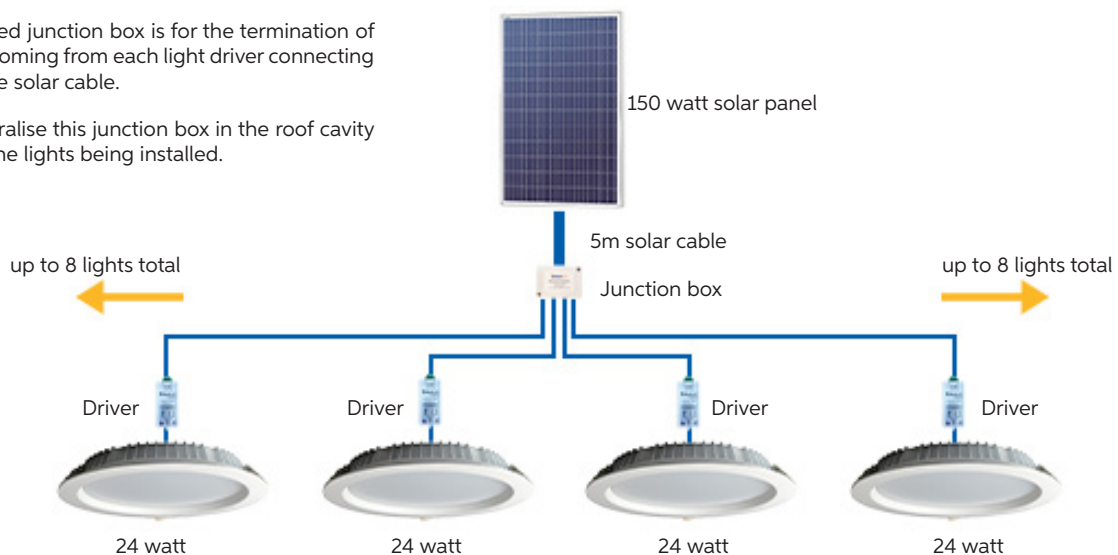

## Connect DC cable to solar panel

- Always follow electrical wiring standards applicable to your location.
- Route the DC cable (C) from your solar panel through the roof cavity to the location where the Redilight fitting is to be installed.
- If installing two lights that are opposite ends of the building then create a central junction point between both lights to alleviate any light differential.

## Mounting the light fixture

### 24 watt slimline surface light fitting

- Once the location for the light fitting is established, centrally create a 20mm hole to allow the light fitting plug & cable to pass through (Fig 14) for connection to the Redilight driver which is located in the ceiling cavity.
- Mount the light fitting to the ceiling (Fig 15) using three screws for a secure fix. Be careful not to damage the LED plate when mounting.
- Now fit the diffuser by simply aligning the three slots and turn anti-clockwise (approx 1/4 turn) until firm and tight (Fig 16).
- Proceed to connecting the driver

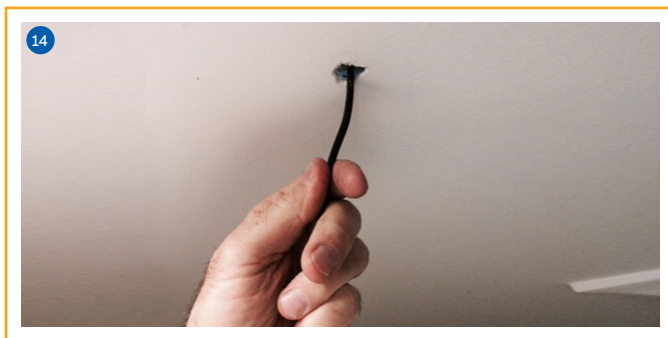

### 24 watt recessed light fitting

- Cut a hole in the ceiling while being mindful to avoid any building structure or services (Fig 18)
- Pull back the 3 spring clips on the downlight (Fig 19) and gently fit into the hole then allow the clips to spring back against the top side of ceiling to secure the downlight to the ceiling.
- Proceed to connecting the driver

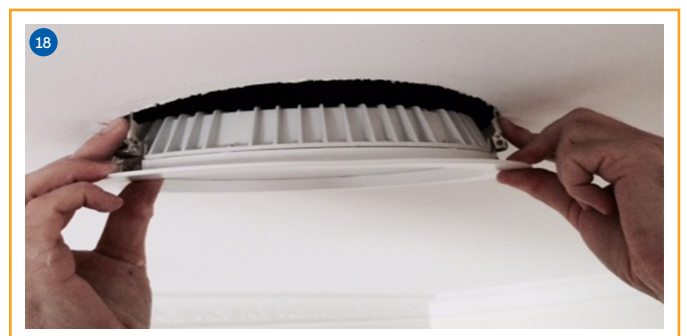

## Connecting the Redilight driver

- Connect the solar panel cable to the green plug on the Redilight driver (Fig 19) The red wire connects to positive (+) and the black wire to the negative (-) .
- Once solar panel connection is complete, plug in the light fitting connector (Fig 20) (Note: If no lights come on once connection is complete then check polarity.)
- Do not cover the driver with insulation. Best practice is to be mount driver to building frame (Fig 21) above insulation line.

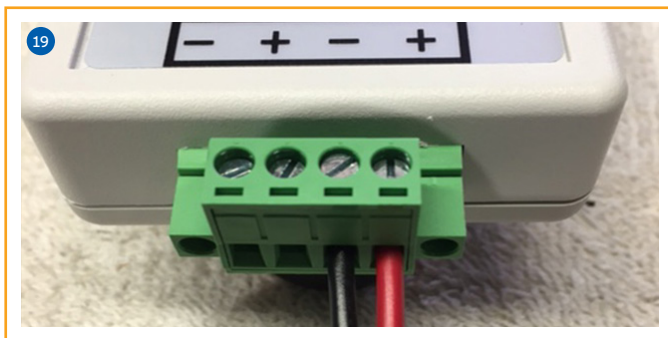

- A secondary light driver can be daisy-chained from an existing light driver if necessary.
- Utilise the secondary terminal points (Fig 19) on the existing light driver and connect to the secondary light driver using the solar cable.
- Do not daisy chain more than three (3) drivers in any sequence.

## Meter box sticker

- Adhere the meter box sticker inside your electrical meter box. (Fig 22)



## Redilight Warranty Policy

Thank you for choosing Redilight Products. In order to guard both seller and buyer interests, Warranty Terms and Conditions are specified by Redilight below. This Warranty applies to Redilight Products only sold by authorised Redilight dealers.

In addition to guarantees afforded under Australia Consumer Law we provide a warranty of:

- 7 year warranty on Redilight LED light fittings (Skyfixtures).
- 5 year warranty on Redilight 'SPECTRA' and 'ORSOM' Drivers.
- 5 year warranty on all Redilight approved parts and accessories.
- 12 month warranty on Redilight remote control handset.
- Solar Panels - 5 year warranty on materials and workmanship, 10 years 90% of rated output, 25 years 80% power output.

The warranty period starts from the date of the purchase of the Product. Redilight warrants that each product will be free from defects in material and workmanship. If a product fails to operate, Redilight shall provide free replacement of the failed product subject to the warranty policy and limited warranty terms and conditions set forth below.

- 1) The limited warranty only applies when the product has been properly wired, installed and operated within the electrical values, operating range, environmental conditions provided in the product specifications, application guidelines and other document provided by Redilight.
- 2) The limited warranty is void if the product is not used for the purpose for which it has been designed.
- 3) The limited warranty is void if any external products that are not approved by Redilight are used in conjunction with the Redilight system.
- 4) This warranty does not apply to damages or defects arising as a result of abuse, improper power supply, misuse, abnormal use or use in violation of any applicable standard, code and instructions.
- 5) The warranty shall be void in the event of any repairs or alterations made to the product by any person not duly authorised by Redilight in writing.
- 6) If the Product is purchased from a Redilight authorised dealer, the Warranty claim must be reported to the Redilight authorised dealer (the original place of purchase) first.

All warranty periods mentioned are subject to a Redilight representative having access to the failed products or systems for verification. Warranty Claims must be reported to Redilight or a Redilight authorised dealer within 30 days after the discovery, specifying at least the following information:

- Detailed problem descriptions which includes photo, video (on request) or other proofs i.e. Invoice, application and operating environment.

Where the Warranty Claim is justified, Redilight shall repair or replace the failed product. Redilight is not responsible for any freight costs incurred. For purpose of clarity, the replacement or repair of the faulty product does not include removal and/or re-installation expenses.